

GIFT WRAPPED

Staff members of *Quilter's Newsletter Magazine* have been designing quilts for our free spring, birthday, and Christmas Memory patterns for decades. This year's Christmas pattern, *Gift Wrapped*, was designed by editorial assistant Penny Conyers. Use fusible web to applique the Christmas lights or embellish your quilt with a purchased string of miniature Christmas bulbs.



Rotary Cutting

Measurements include 1/4" seam allowances. Align arrows with lengthwise or crosswise grain of fabric.

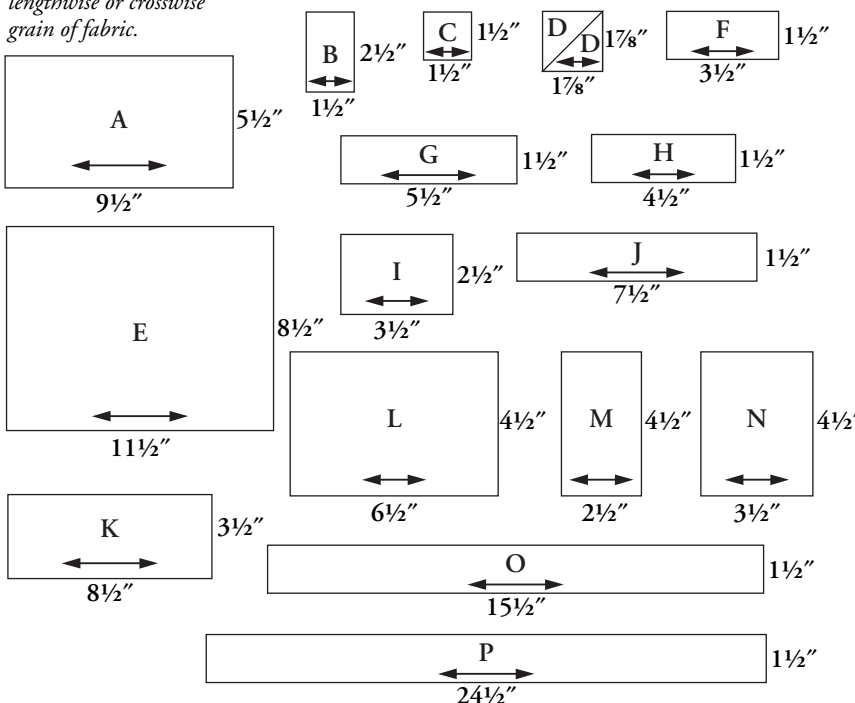

MATERIALS AND CUTTING

Requirements are based on 40" fabric width.

Quilt Size: 24" x 17"

Materials	Yds.	Cutting
White	fat 1/4	1 A, 5 B, 2 C, 10 D, 1 E, 1 H, 2 O
Lt. Blue	scrap	7 C, 12 D
Dk. Blue	3/8	4 C, 6 D, 2 O, 2 P, 3 strips binding 2 1/2" x 40"
Green	scrap	4 D, 1 L
Red	scrap	1 B, 1 H, 1 J
Pink	scrap	2 I, 1 M, 1 N
Gold	fat 1/8	2 B, 5 C, 12 D, 2 F, 2 G, 1 K
Backing	5/8	21" x 28"

Batting 4" wider and longer than quilt top

Also needed: For appliqued Christmas lights: scrap of black fabric, black embroidery floss, and scrap of fusible web. Optional: purchased string of miniature plastic Christmas lights.

Techniques used: machine piecing, fusible applique

Assembly

① Wash and press fabrics. Cut the patches listed in the materials and cutting box and shown in the rotary cutting diagrams. If desired, use a washout fabric marking tool to label the wrong side of each patch with its patch letter.

② Refer to the assembly diagram to position patches on a tabletop or design wall. Assemble units as shown, and then sew units into rows 1, 2, and 3 as shown. Join rows, and then sew a white O to each side of the quilt.

③ After testing your fabric marking tool on a scrap of background fabric, lightly mark a curved line across the top right corner of the quilt to indicate the placement of the string of Christmas lights. To place a purchased string of miniature plastic Christmas lights, skip to step 5.

④ With black embroidery floss, stitch along the placement line, using a basic chain, outline, or stem stitch. Trace a bulb onto the paper backing of a small piece of fusible web. Cut out the fusible patch $\frac{1}{4}$ " beyond the marked lines. Press the web to the wrong side of a colored scrap, and then cut out the bulb along the lines. Repeat to make 7

bulbs. In the same way make 7 bulb bases from black fabric. Peel the paper backing away from each piece. Arrange bulbs and bulb bases as desired along your embroidered string, slightly overlapping the straight end of each bulb with a bulb base. Press to fuse. Stitch around appliques with a narrow zigzag or buttonhole stitch. Skip to step 6.

⑤ To embellish your quilt with a purchased string of miniature Christmas lights, stitch in place by hand, or use a narrow zigzag stitch to couch the string by machine along your placement line. If the plastic bulbs get in the way of your presser foot, you may need to try an open-toe foot, or drop your feed dogs and free motion zigzag with a darning foot.

⑥ Sew blue O's to the sides of the quilt, and then sew blue P's to top and bottom of quilt.

⑦ Layer the quilt backing, batting, and top. Baste. Quilt in-the-ditch around the bows, ribbons, and packages and around the applique. Quilt an allover design in the background, or quilt the outlines of additional packages or lights. Bind the quilt to finish. ♦

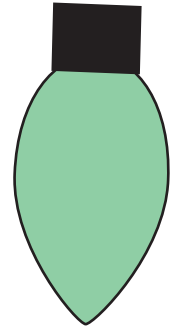

BULB AND BASE
Make 7

